



# Industrial Model

 SMARTZ  
Biometric Attendance & Access Control System

 STAR LINK<sup>®</sup>  
Your needs.... Our Solutions !

# Introduction

Industrial Model, another state-of-the-art from STAR LINK serving its purpose of maintaining attendance records of the employee in Industries or big set-ups. The Industrial Model comes in heavy metallic body for dusty and harsh environments. It has 65,000 records storage capacity with 25,000 fingerprint templates storage capacity.

The Industrial Model features LCD display to show the information of the employees whereas 2 large lights (Red & Green) indicates the status of the attendance. The built in TCP/IP connectivity helps to get the data on a single click of mouse. It features heavy duty battery back-up of up to 48 hours, which makes it more compatible with the industrial environments.

# Features

- Large LCD display
- 65,000 recording capacity
- 25,000 fingerprint template storage
- Heavy duty metallic body
- Built-in battery back-up up to 48 hours
- Built-in TCP/IP connectivity
- Large Red/Green indicators
- Built-in camera for photo capturing (optional)
- Customization possible (according to the requirement)

# Specifications based on the usage

Reader Type	SMART CARD	PROXIMITY CARD	FINGERPRINT
Model No.	SC – 06	PC – 06	FP - 06
Processor	32 Bit RISC	MC 32 Bit RISC	MC 32 Bit RISC MC
Card Type	Smart Card 1K, 4K	EM Card 512 Byte	EM Card / Smart Card
Read Range	Up to 60 mm	Up to 120 mm	Up to 60 / 120 mm
Frequency / Modulation	13.56 Mhz.	125 Khz.	125 Khz / 13.56 Mhz.
Identification Time	Less than 1 sec.	Less than 1 sec.	Less than 1 sec.
Display	LCD 16 x 2 Character	LCD 16 x 2 Character	LCD 16 x 2 Character
Memory Transaction	62,500 records	62,500 records	62,500 records
Card Masking	15,000 records	15,000 records	2000 / 9560 records
Communication Mode	RS 232, TCP/IP	RS 232, TCP/IP	RS 232, TCP/IP
Operating Temperature	5 to 50 degree Celsius	5 to 50 degree Celsius	5 to 50 degree Celsius

### Reader Type

Operating Humidity  
Operating Voltage  
Dimension (in mm)  
Weight  
Keypad  
Audio/Video Indicators

### SMART CARD

10 to 90%  
DC 12V, 500 mA  
H=183,W=131,B=58  
600 gms.  
4 x 4 Keypad  
Buzzer / LED

### PROXIMITY CARD

10 to 90%  
DC 12V, 500 mA  
H=183,W=131,B=58  
600 gms.  
4 x 4 Keypad  
Buzzer / LED

### FINGERPRINT

10 to 90%  
DC 12V, 500 mA  
H=183,W=131,B=58  
600 gms.  
4 x 4 Keypad  
Buzzer / LED

# Operational Modes

- Only finger
- Only card
- Finger in card
- Card with Password
- PIN
- Password
- Card with finger



# Fingerprint Scanner

- Sensor Technology: Optical CMOS
- Sensing Area: 16.0mm × 19.0mm
- Image Size (Pixels): 272 × 320
- Image Resolution: 500 dpi
- Finger Verification Option: 1:N (Only Finger)
- Finger Template Size: 384 bytes.
- EER < 0.1%
- Enrollment Time: 1~1.5 Sec
- Verifications < 0.8 Sec
- Identification Time: 1~1.5 Sec
- FingerPrint storage: 25,000



# Time Zone

Time Zone is one of the feature which helps to restrict the acceptance of transaction in that time interval. It is normally used in Canteen management system(with printer) and tea/coffee vending machine.

The Time Zone can be managed through Data Capture software and as a whole 10 time zones can be assigned with different time intervals.

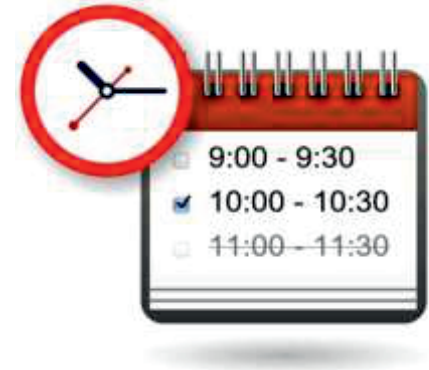

# Remote Device Management

Remote Device Management allows us to manage the devices installed at multiple location with ease. Without physical manipulation, Industrial Model allows user to do certain things through “**web-based management module**” which eases the operation of device. Also, you can manage device location wise, dept. wise etc.

- Finger Enrolment from any location
- Addition/Deletion of USER list
- Change password of Device
- Data Deletion
- Date-Time Set
- Sending finger through server
- Multiple location device management
- 2-way communication through Static IP



# Other Utilities of Industrial Model



# Access Control

Access Control is installed in office premises to restrict the unwanted movements. Access Control Systems are made up of three important mechanisms: a controller, the locks and the access device. Industrial Model can be used as the access device for successful operation. It also generates "**IN** and **OUT**" report for maintenance of records.



# Hooter Interface

Hooter interface is used to be connected with alarm or hooter that can be fixed through the biometric device, which is used for attendance. Industrial Model can be used for accurate and precise working. It is basically an interface, connected through the serial port with Industrial Model.



# Guard Tracking System

Industrial Model can be used for Guard Tracking application. These devices are installed at certain check-points in the periphery of the company, where guards shows their cards to machines in fixed time intervals. It generates the report of each transaction done in every machine. You have to use Smart card for the easier operation of this system.



# Tea/Coffee Vending Machine

Industrial Model can be used in Tea/Coffee vending management, as time zone comes into action in its operation. You can limit the usage of Tea/Coffee vending machine according to policy on the basis of employee/department/group. Also, you can recharge the prepaid/postpaid card through this system.



# Canteen Management System

Keeping in mind about many complexities related to the management of employees in Canteen area, STAR LINK has designed Canteen Management System, which is a perfect solution for the management of canteen facilities for employee. It restricts the unauthorized usage of canteen facility. This software helps to automate the process and make it transparent. It reduces the chaos created during the lunch or dinner timing, helping to manage the service swiftly. Industrial model with thermal Printer is used to print the coupon as transaction takes place.



# Industrial Model with Printer

Industrial Model with printer is also one of the biometric devices developed by STAR LINK. It has been designed with thermal printer, which is normally used in canteen management system. It prints coupons as any transaction takes place. And other features are exactly as like other Industrial model of Attendance System.



# Industrial Model of Bio-LYNX

STAR LINK also offers its Bio-LYNX model in Industrial Model with heavy duty metallic body and 48 hours battery back-up. This industrial model perfect for harsh environmental conditions.

Also, there is optional built-in camera which is normally used for double layer verification as it captures image of the person (registered or unregistered) who tries to transact through device. And all other features are same as Bio-LYNX.



# Wired Connectivity

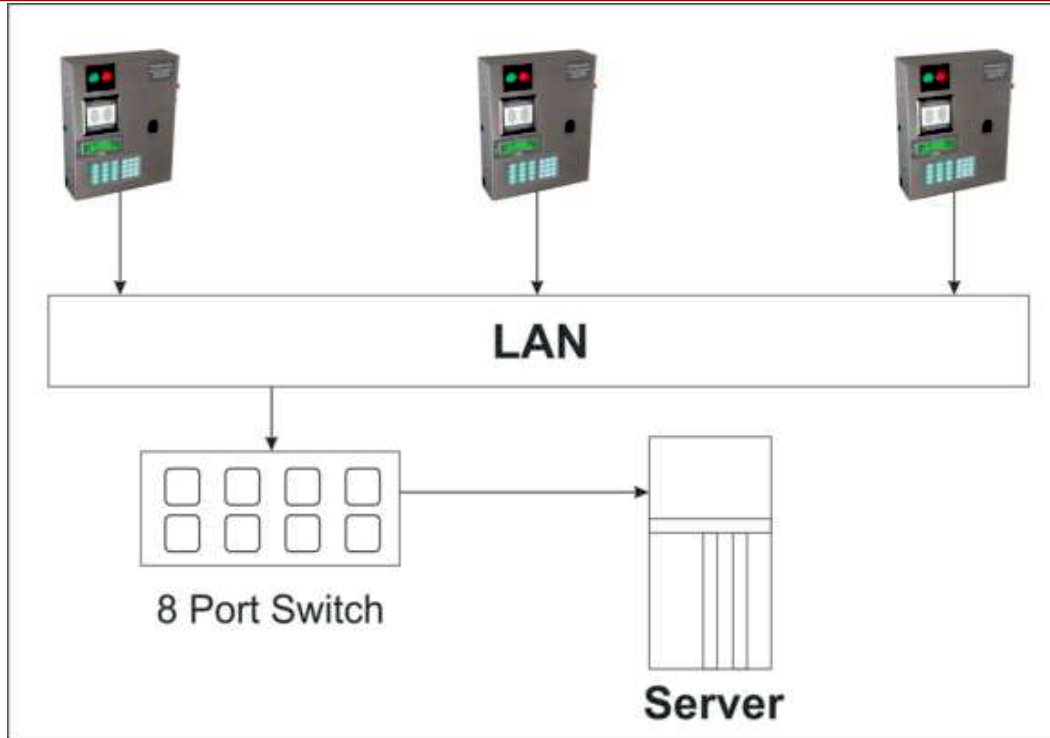

# Service & Support



# Conclusion

Industrial Model is a robust and rugged machine with 48 hours battery back-up with metallic body makes it a perfect choice for industrial conditions. This machine is packed with every features and specifications which helps you to serve different purpose effectively.

# THANK YOU...